



SETIMEP

Engenharia • Ambiente • Energia
Engineering • Environment • Energy

HIGH PRESSURE FAN

**MODEL:
SET.VT.CAP**

PRODUCT DESCRIPTION

The High-Pressure Centrifuge fan is a turbo machine that produces the displacement of gases. It consists of a rotor with paddle actuated by a motor.

The rotation of the assembly rotor + paddle promote the transformation of mechanical energy from the motor in potential pressure energy and kinetic energy

TYPE OF CONSTRUCTION

Welded construction in structural carbon steel S235JR
(Manufacturing with specific dimensions and, material on request)

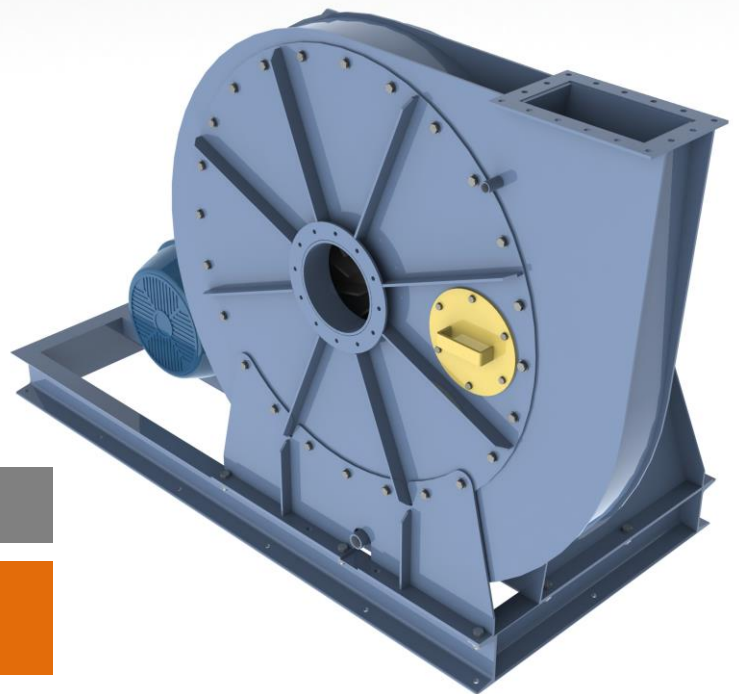

AVAILABLE RANGE

4 different aerolic families, that permit blowing any kind of fluids achieving flow rates to 11m³/s (40 000 m³/h) with pressures from 250 to 1600 mmca

Blower with variable diameter of profile adapted to the fluid (absolutely clean air or air loaded of particles) with efficiency to 82%

For more information contact us

CODIFICATION/REFERENCE

SET . VT. CAP . 0008

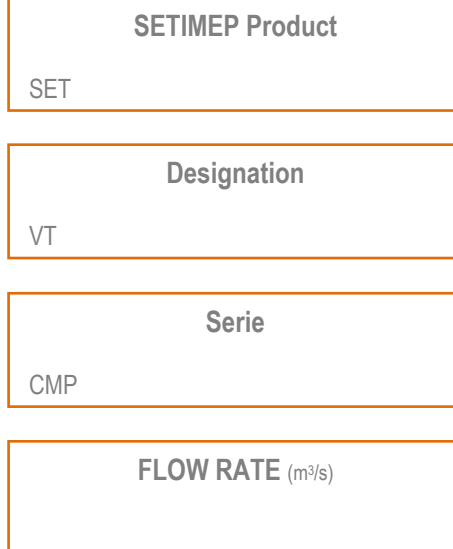

Ex: SET.VT.CAP.0020 → High Pressure Fan for a flow rate of 8 m³/s

HIGH PRESSURE FAN

MODEL: SET.VT.CAP

TECHNICAL SPECIFICATIONS

ORIENTATIONS

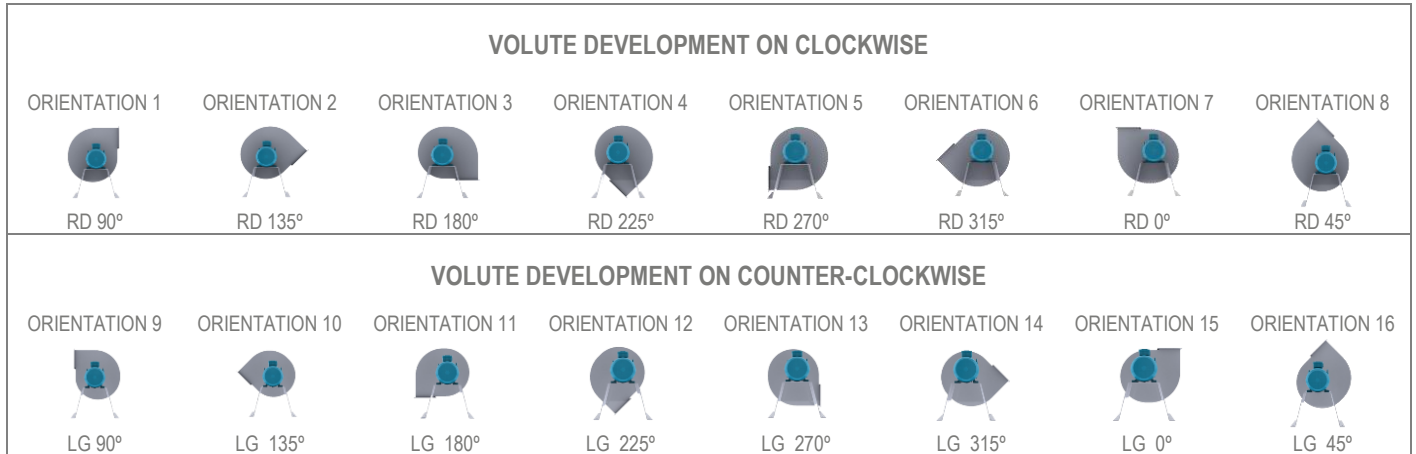

ASSEMBLY POSITION

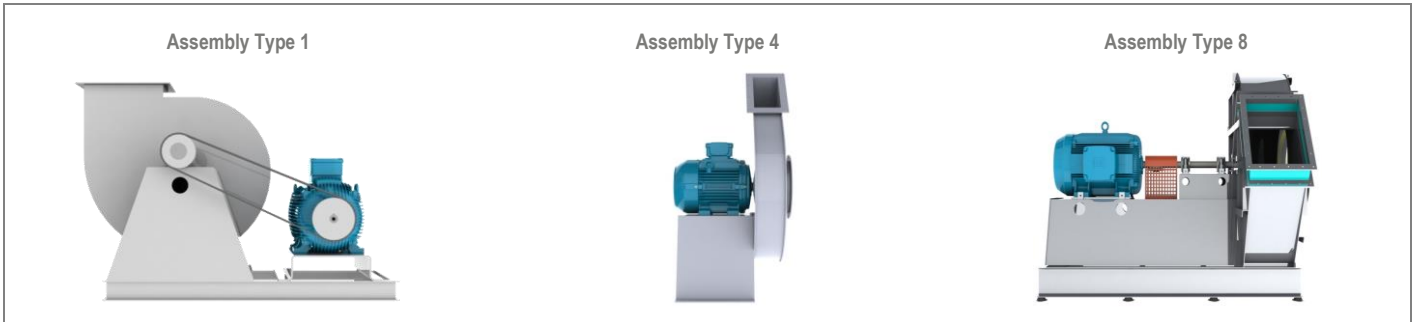

OPTIONS

Aspiration

- 1 - Counter Flange
- 3 - Flow Tilting Regulation
- 4 - Grid
- 5 - Aspiration flexible joint
- 6 - Protection Filter

Operation

- 10 - Chassis
- 11 - Transmission
- 12 - Protection Transmission
- 13 - Protection Motor
- 14 - Protection Exterior
- 15 - Buffers
- 16 - Motor
- 17 - Cooling Blower
- 18 - Sealing Gasket

Impulsion

- 7 - Counter Flange
- 8 - Impulsion flexible joint

Others

- 19 - Inspection Doors
- 20 - blower volute purge
- 22 - Lubrication cup
- 23 - Any Kind of finishing

Special Components

- a) Impulsion protection grid
- b) Impulsion register
- c) Silencer
- d) Rotation sensor
- e) Venturi

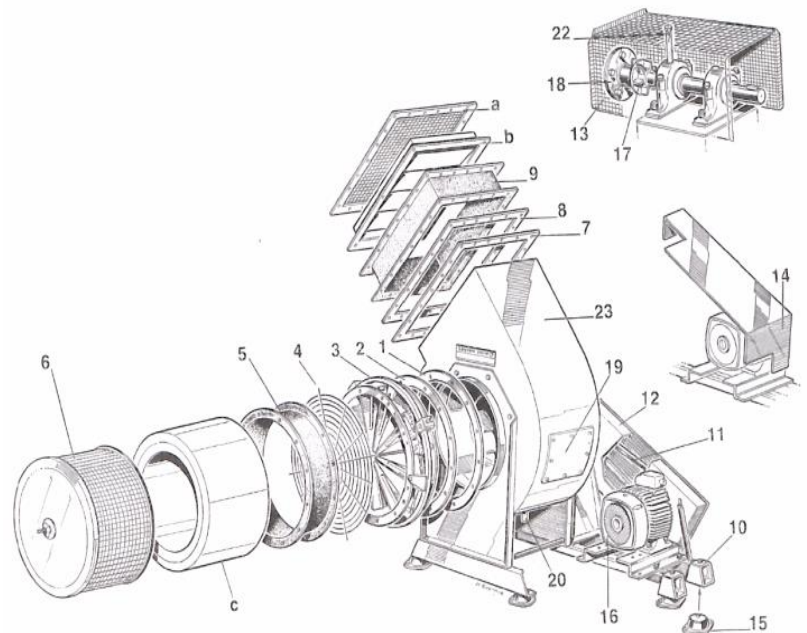

SETIMEP, LDA

Rua Óscar Dias Pereira, 84 - Gualtar 4710-081 Braga | T. +351 253 679 469 | F. +351 253 679 478 | info@setimep.com | www.setimep.com

CAPITAL SOCIAL 50.000 EUROS, MATRICULADA NA CONSERVATÓRIA DO REGISTO COMERCIAL DE BRAGA, SOB Nº 6648 DFE 14/10/99, PESSOAL COL. Nº 503002780