



SETIMEP

Engenharia • Ambiente • Energia
Engineering • Environment • Energy

CYCLONE

MODEL:
SET.CI.AEF.****

PRODUCT DESCRIPTION

Cyclone for separation and catchment of granulated products using rotary air movement to separate particles

Constituted by a cylinder where the air entry is done tangentially to the radius. On the inferior side of this cylinder we could find the cone that promote the gas flux inversion, the clean air pass through the external cylinder located in the superior side of the cyclone.

TYPE OF CONSTRUCTION

Construction in structural steel S235JR
(Fabrication with specific dimensions and materials on request)

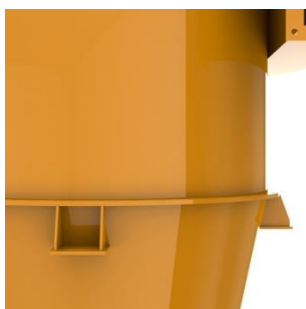
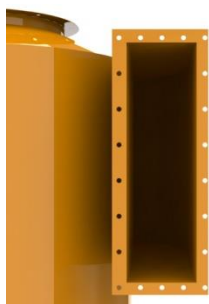

SETIMEP Product
SET

Designation
CI

Serie
AEF

FLOW RATE (x10³ m³/h)
0002.....0055

AVAILABLE RANGE

For flow rates of 2.000 up to 55.000 m³/h
(See table below)

CODIFICATION / REFERENCE

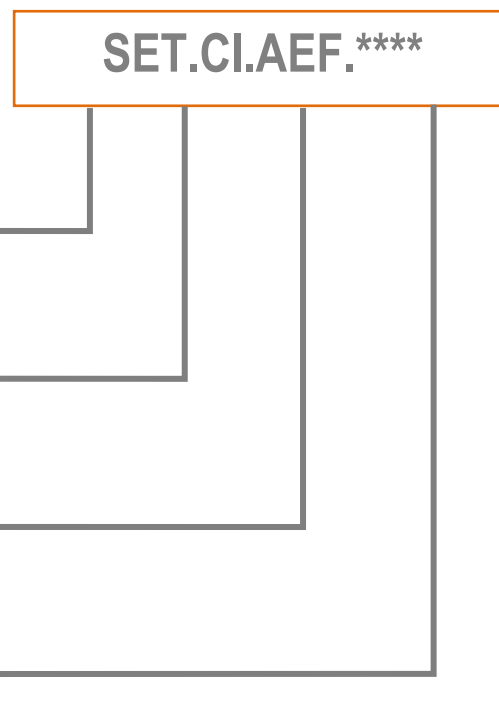

Ex: SET.CI.AEF.0020 → Cyclone for a flow rate of 20.000 m³/h



HIGH PERFORMANCE CYCLONE

MODEL: SET.CI.AEF.****

TECHNICAL CHARACTERISTICS

MODEL	ØA (mm)	ØB (mm)	ØC (mm)	D (mm)	E (mm)	F (mm)	FLOW RATE
SET.CI.AEF.0002	525	200	250	2100	350	125	2.000 (m³/h)
SET.CI.AEF.0003	600	200	300	2500	425	150	3.000 (m³/h)
SET.CI.AEF.0004	700	250	350	3000	500	175	4.000 (m³/h)
SET.CI.AEF.0005	750	280	400	3150	575	175	5.000 (m³/h)
SET.CI.AEF.0006	800	300	425	3350	600	225	6.000 (m³/h)
SET.CI.AEF.0008	950	350	500	3925	700	225	8.000 (m³/h)
SET.CI.AEF.0010	1000	400	550	4500	950	225	10.000 (m³/h)
SET.CI.AEF.0012	1100	400	600	5250	1100	225	12.000 (m³/h)
SET.CI.AEF.0015	1400	555	700	6250	1200	300	15.000 (m³/h)
SET.CI.AEF.0020	1600	600	800	6250	1400	325	20.000 (m³/h)
SET.CI.AEF.0025	1800	650	900	7550	1500	350	25.000 (m³/h)
SET.CI.AEF.0035	2100	800	1100	8750	1700	450	35.000 (m³/h)
SET.CI.AEF.0045	2400	900	1250	10050	1900	550	45.000 (m³/h)
SET.CI.AEF.0055	2700	1000	1350	11200	1950	600	55.000 (m³/h)

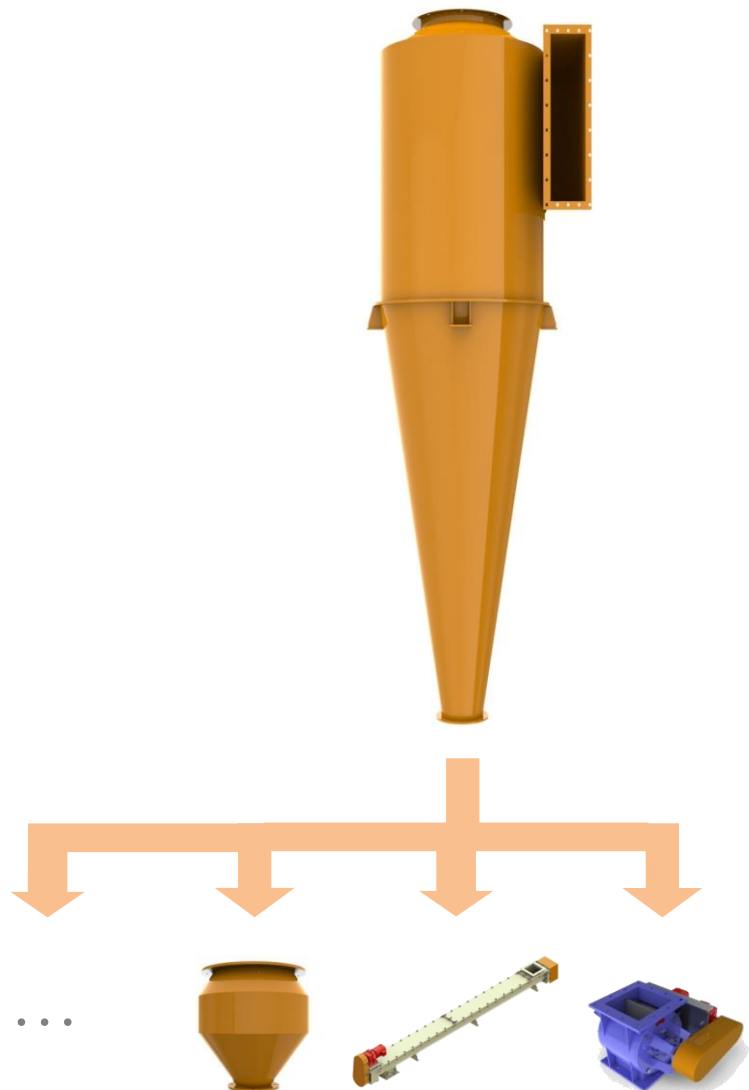
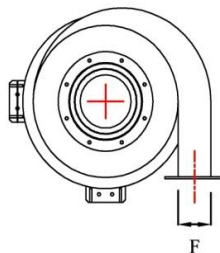
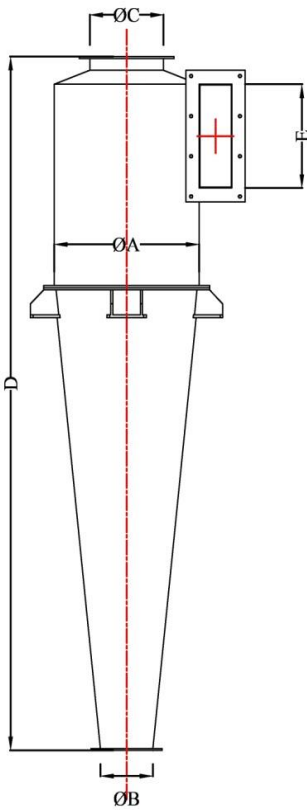

SETIMEP, LDA

Rua Óscar Dias Pereira, 84 - Gualtar 4710-081 Braga | T. +351 253 679 469 | F. +351 253 679 478 | info@setimep.com | www.setimep.com

CAPITAL SOCIAL 50.000 EUROS, MATRICULADA NA CONSERVATÓRIA DO REGISTO COMERCIAL DE BRAGA, SOB Nº 6648 DFE 14/10/99, PESSOAL COL. Nº 503002780